

Installation and Operating Instruction for B.E.G. - occupancy detector PD2N-LTMS-RR-FC

1. Product information

- Multisensor (presence, temperature, brightness detection) for connection to proprietary bus systems
- Output of the current light and temperature value as analog voltage
- Low noise Reed Relays
- Other functions via remote control adjustable

2. Operation

The presence detector has sensors for presence; Temperature and brightness detection which are suitable for connection to proprietary bus systems. The output of the signals takes place by analog voltage values 0-10V (10LUX = 0.1 V, 0.5 °C = 0.1 V) at the output terminals. For evaluating the motion detection a floating reed relay is still available.

3. Safety information

- ⚠ Work on the mains supply may only be carried out by qualified professionals or by instructed persons under the direction and supervision of qualified skilled electrical personnel in accordance with electrotechnical regulations.**
- ⚠ Disconnect supply before installing!**
- ⚠ This device is not suitable for disconnection.**

4. Mounting

A circular opening of diameter 68 mm must first of all be produced in the ceiling.

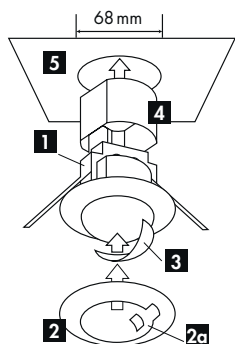

- 1) Using the sensor
- 2) Plug-in ring cover, including cover for LEDs (2a)
- 3) Cover slat (if necessary)
- 4) Protective cover
- 5) Ceiling (68 mm diameter hole, drilled)

Having connected up the cables in accordance with regulations, the detector is inserted into the opening as shown in the drawing opposite and fixed into position with the assistance of the spring clip.

5. Hardware configuration FC

Position LED's and potentiometer

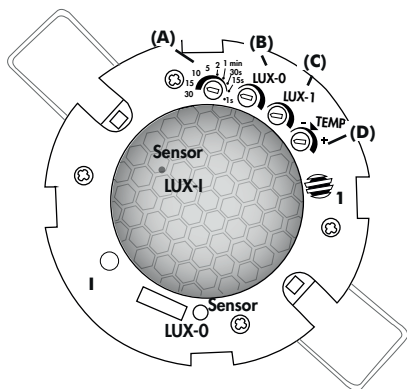

- Potentiometer (A): Potentiometer Follow-up time
- Potentiometer (B): Potentiometer Brightness adjustment LUX-0
- Potentiometer (C): Potentiometer Brightness adjustment LUX-1
- Potentiometer (D): Potentiometer Temperature setting TEMP

LED I: red

- Sensor (LUX-0) : Brightness
- Sensor (LUX-1) : Brightness
- Sensor (1) : Temperature

6. Self test cycle/Startup behavior

The product enters an initial 60-second self-test cycle, when the supply is first connected. During this time the device does not respond to movement and stays on.

7. Putting into operation / Settings

Adjustment follow-up time "motion detection"



The follow-up time can be set from 1 sec to 30 min.

Brightness adjustment LUX-0



The potentiometer LUX-0 can set fine adjustment of the light output value

Brightness adjustment LUX-1



The potentiometer LUX-1 can set fine adjustment of the light output value

Temperatur Offset



With potentiometer TEMP, an offset can be set (+4 °C to -4 °C)

8.1 Brightness adjustment

With the potentiometers LUX 0 and LUX-1, the output voltage of the 0-10V output of + / - 10% change and the slope of the lux / VDC curve can be adjusted. Losses caused by cable lengths can be compensated.

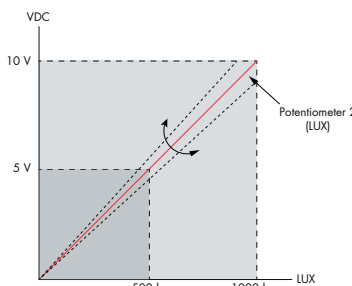

8.2 Brightness value output as a voltage value the LUX-terminal

The brightness value output corresponds each 10LUX = 0.1 V
The brightness measurement includes the area between 0LUX = 0V to 10V = 1000 lux
An update of the measured values are approximately every 0.5 s

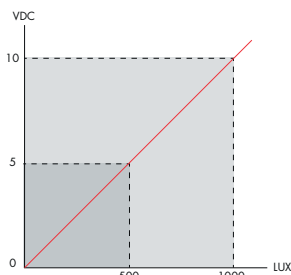

8.3 Temperature adjustment

With the TEMP potentiometer output voltage can be offset between -4°C (-0.8V) to 4°C (0.8V) regarding to the temperature measured by the temperature sensor in order to compensate the measurement of the sensor depending where the device is placed. The neutral position of the potentiometer is marked with an arrow where the 0 offset is.

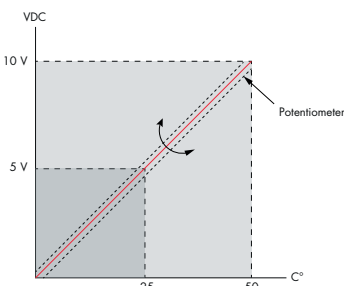

8.4 Temperature value output as a voltage value to the TEMP terminal

The temperature value output corresponds each 0.5 °C = 0.1 V. The temperature range is the range between 0 °C = 0 V and goes to 50 °C = 10V is done to update the readings approximately every 10s

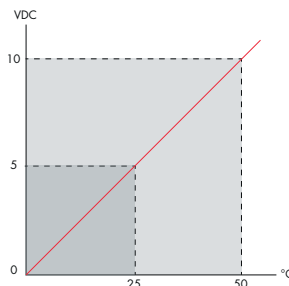

9. Motion detection

The motion sensor turns on the relay with active motion and turns off when the unit detects no movement and the follow-up time has expired. After switching off the motion detection for about 2s is deactivated to prevent an unwanted power up again. An update of the measured values are approximately every 20ms.

10. Exclude sources of interference

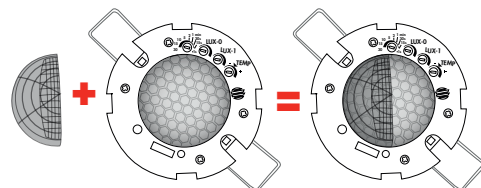

If the detection zone is too large, or areas covered that should not be monitored, use the blinds to reduced or limited those areas.

11. Range of Coverage

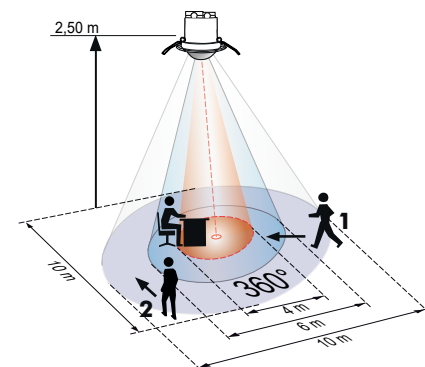

- 1 walking towards
- 2 walking across
- 3 seated

12. Technical data

Power supply: 16-48 VDC < 1W
Power consumption: 1W
Ambient temperature: 0°C to +50°C
Degree of protection /class: IP20 / II
Settings: Potentiometer and Remote control
LUX-/TEMP-Output: 0-10 V ± 200 mV, 10 mA max.
Light values
Sensitivity: 0 - 1000 Lux, ± 20 Lux
Light measurement: ca. 10 mV/Lux
Temperature values: 0°C - +50°C, ± 0,5°C
Sensitivity
Temperature values: ca. 200 mV/°C
Area of coverage: circular 360°
Range of coverage
Ø H 2,50 m / T = 18°C: tangential 10 m / frontal 6 m

Recommended height for mounting: 2 - 3 m
Light measurement: mixed light
Motion detector: potential-free contact NO, µ max. 48 VDC, 100mA, cos φ=1
Contact load: Potentiometer
Time setting (Channel 1): 1s. - 30 min. Remote control 5s - 1h or Impuls function single wire (not stranded) 0,34... 1,5 mm² single conductor max. 100 m*

Connection: single wire (not stranded) 0,34... 1,5 mm² single conductor max. 100 m*

Cable length: max. 100 m*

*Avoid parallel wiring to power cables. If a separated installation is not possible, the use of shielded cables is recommended

Dimensions H x Ø [mm] 83 x 83 mm
Visible portion when built into ceiling: 20 x 83 mm
 Sensor and power supply in one case

CE Declaration of Conformity:

This product respects the directives concerning

1. electromagnetic compatibility (2014/30/EU)
2. low voltage (2014/35/EU)
3. restriction of the use of certain hazardous substances in electrical and electronic equipment (2011/65/EU)

13. Article / Part nr. / Accessory

Typ	FC
PD2N-LTMS-RR	92119

LUXOMAT® Remote control: IR-LTMS (incl. wall bracket) 92185

Accessory: BSK Ball basket guard 92199

14. LED function displays

LED function indicators	
Operating state	LED function indicators
Initialization	60s initialization, red flashes 2x in the second
Active	red lights on when motion is detected

Resetting the Temperature potentiometer on neutral, LED lights up for 2 seconds.

15. Connections

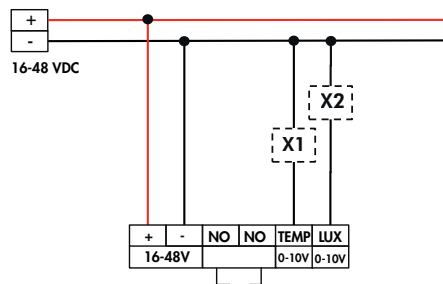

X1, X2: Evaluation units/-devices

16. Putting into operation of the remote control IR-LTMS (optional)

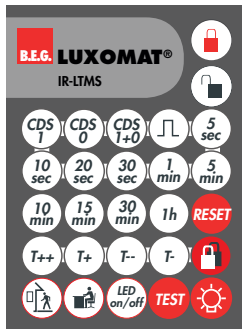

IR-LTMS



Wall bracket for remote control IR-LTMS

17. Settings by remote control when open

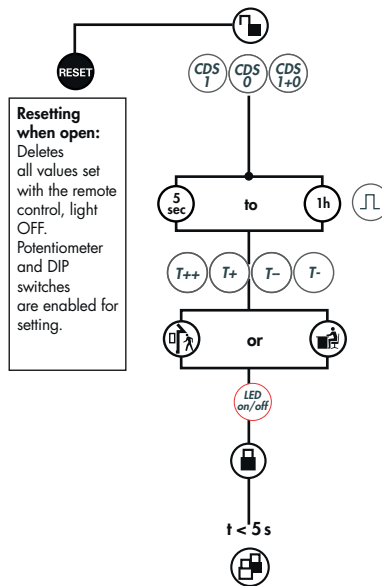

Explanation of the remote control button functions

CDS 1 Factory setting: In this setting, the light measurement take place over light sensor **LUX-0**

CDS 0 In this setting, the light measurement takes place via light sensor **LUX-I**

CDS 1+0 In this setting, the light measurement take place over an average of the two light sensors.

Impuls function

5 sec Follow-up time

1h

Reset in the open state: Deletes all values set with the remote control, Potentiometer settings apply.

Resetting when closed: End all active follow-up Timer

T++ Increase the temperature offset to +1°C (0,2V)

T+ Increase the temperature offset to +0,5°C (0,1V)

T-- Reduce the temperature offset to -1°C (0,2V)

T- Reduce the temperature offset to -0,5°C (0,1V)

Lock icon This function permanently blocks the reception of remote control signals. This function can be activated within 5 sec. after closing the detector. To unlock see 18. Reset the permanent sabotage protection

Normal sensitivity icon Normal sensitivity

High sensitivity icon High sensitivity

LED on/off icon Activate or deactivate the LED display

TEST Test mode, only dependent on movement. With every movement switches the light for 2 seconds ON, then for 2 sec. OFF. After 3min. Test mode is automatically terminated and returns to normal operating mode.

Light icon To turn the light on and off manually by pressing the button briefly. The light will remain on or off as people are detected plus the follow-up time.

18. Reset the permanent sabotage protection

If the permanent sabotage protection is activated, the detector can be released again as follows:

- Switch off the power supply and switch it back on
- Switch the power supply off again after 31 seconds of the initialization and before 59 seconds
- Apply power again and wait for the self testing
- Press the unlock

19. Selection of the light sensors

The product PD2N-LTMS-RR used a light sensor, to determine the brightness value by default, which is located in the outer cover ring. Through this arrangement, results a selective range, where the light measurement takes place. For an enlargement of the selective measurement range, a second light sensor (behind the lens) can be switched on or get individually activated by the optional remote control.

Sensor **(LUX-0)** Light sensor in the cover ring (Factory setting)

Sensor **(LUX-1)** Light sensor behind the lens

20. LED-functional indicators

LED function indicators	
Operating state	LED function indicators
Remote control signal	LED flashes briefly
Detector close	LED shines 5 sec.