

**Presence detector and motion detector 360° compact**  
 Order No. : 2399 02

**Operating instructions**

**1 Safety instructions**



Electrical devices may only be mounted and connected by electrically skilled persons.

**Serious injuries, fire or property damage possible. Please read and follow manual fully.**

**Danger of electric shock. Device is not suitable for disconnection from supply voltage.**

**Danger of electric shock. Always disconnect before carrying out work on the device or load. In so doing, take all the circuit breakers into account, which support dangerous voltages to the device and or load.**

**Do not press on the sensor window. Device can be damaged.**

**Keep button cells out of reach of children! If button cells are swallowed, get medical help immediately.**

**Risk of explosion! Do not throw batteries into fire.**

**Risk of explosion! Do not recharge batteries.**

**The device is not suitable for use as a burglar alarm or other alarm.**

**These instructions are an integral part of the product, and must remain with the end customer.**

**2 Device components**

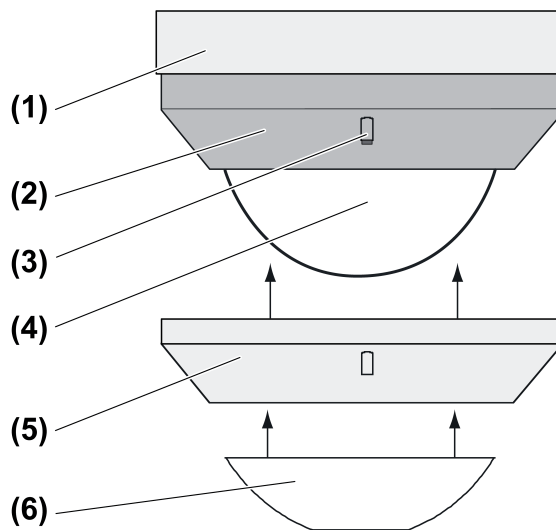

Figure 1

- (1) Connection box
- (2) Sensor top
- (3) Brightness sensor
- (4) Sensor window with red and blue display LED
- (5) Decor ring
- (6) Push-on cover

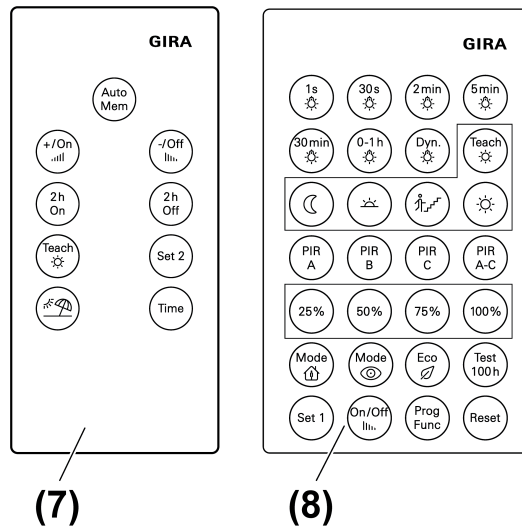

Figure 2

- (7) IR PIR 2 remote control (end customer), included in the scope of delivery  
 (8) IR PIR 1 remote control (installation engineer), see Accessories

### 3 Function

#### Intended use

- Automatic switching of lighting depending on the heat motion and ambient brightness.
- Indoor ceiling mounting, surface-mounted

#### Product characteristics

- 2-point light control
- Functions settable with IR remote controls
- Restriction of the detection field by switching off individual sensors or push-on cover.
- Operation with IR remote control, 2-wire extension or installation button
- Teach function for adjustment of the brightness threshold, in combination with IR remote controls
- Switch-off warning
- Short-time operation, e.g. to activate acoustic signal encoders
- Display LEDs
- Presence simulation
- Function as twilight switch
- Dynamic run-on time
- Extension of the detection area through parallel switching of multiple devices

**i** The extension of the detection area with 3-wire extensions is not possible.

#### Automatic operation

The device detects heat motions of people, animals and objects.

- The light is switched on if a person enters the detection area and the brightness is below the set threshold.  
The run-on time restarts with each detected motion.
- The light is switched off when it is no longer required because:  
No more movement is detected in the detection area and the run-on time has elapsed or the ambient light is too bright.  
The switch-off brightness is calculated from the set brightness threshold and the connected light.  
To avoid brief shading from causing switch-off, switch-off only takes place when the set run-on time has elapsed. The run-on time does not restart on movement detection for as long as the switch-off brightness is exceeded.

**i** The minimum switch-off brightness is 100 lux, even if a lower value is set.

To avoid any switch-on caused by a cooling illuminant, no movement signals are evaluated for a brief lockout time after switching off. The motion detector adjusts itself to the ambient conditions to keep the time as short as possible.

### Short time operation

If movement occurs, then a short pulse of approx. 0.5 seconds is triggered according to the brightness. The pulse is cyclically repeated as long as motions are detected.

### Switch-off warning

If the switch-off warning is active, the light is not switched off immediately after the run-on time has elapsed. Triple flashing at an interval of 10 seconds shows that the light will be switched off soon. The run-on time is thereby prolonged by approx. 30 seconds. If movement is detected during the switch-off prewarning, then the run-on time is restarted and the light remains on.

### Dynamic run-on time

The function determines a run-on time within specified limits automatically and dynamically from detected movements. In so doing, the run-on time is increased if presence continues or decreased if absence is detected.

### Presence simulation

In automatic operation, the motion detector continuously saves times for which the lighting was switched on. A maximum of 60 switching operations are saved over a period of 24 hours. If more switching operations take place, the oldest ones are overwritten respectively. If the presence simulation is activated, the motion detector switches the lighting at the saved times according to the brightness. Switch-off takes place after the run-on time has elapsed. Detected motions prolong the run-on time or the light is switched on depending on brightness. Times are not saved.

### Function as twilight switch

The function is active as soon as all the PIR sensors have been switched off (see Commissioning). The light is switched according to the brightness. Motions are not evaluated

- The light is switched on if the brightness is below the set threshold for 4 minutes.
- The light is switched off when the switch-off brightness (see Automatic mode) is exceeded for 4 minutes.

**i** Switch-on and switch-off of the light via 2-wire extensions or installation buttons is not possible. The Continuous on/off and on/off for 2 hours functions cannot be used.

### Behaviour after mains return

After mains return, the device performs a self-test for a maximum of 20 seconds. After the self-test has been completed, the device is ready for operation. The device switches the light according to the settings made.

The following applies during the self-test:

- The red and blue display LEDs (4) light up.
- The device cannot be operated or set using an IR remote control.
- Movements are not detected.
- The device can be switched via 2-wire extensions or installation buttons.

## 4 Operation

Special functions can be switched and settings adjusted using the supplied IR remote control.

**i** Special functions can restrict operation via the 2-wire extension inserts or installation buttons.

**i** If multiple devices are within the range of the IR remote control, then align it so that only the device to be operated can receive the signals.









### LED display

Behind the sensor window (4) are a red and a yellow LED (Figure 1) for indicating different states of operation.

<b>Red LED</b>	<b>Blue LED</b>	<b>Signalling</b>
----------------	-----------------	-------------------



Off	On	Light switched on continuously
On	Off	Light switched off continuously or twilight button function activated
Flashing slowly	Off	Presence simulation switched on
Flashing	Off	Receipt of IR signals
Off	Flashing	IR signal detected

## Button assignment of the end user IR remote control

Button	Function
<b>Auto Mem</b> Pressing for less than 0.4 seconds	Switching on automatic mode
<b>Auto Mem</b> Actuation of between 1 and 4 seconds	In automatic mode: Switch-on for the duration of the run-on time
<b>+/On</b>  Pressing for less than 0.4 seconds	Continuous on
<b>-/Off</b>  Pressing for less than 0.4 seconds	Continuous off
<b>2 h On</b> Pressing for less than 0.4 seconds	On for 2 hours
<b>2 h Off</b> Pressing for less than 0.4 seconds	Off for 2 hours
<b>Teach</b>  Pressing for less than 10 seconds	In the next 10 seconds, the brightness threshold can be changed incrementally using the <b>+/On</b>  or <b>-/Off</b>  buttons.
<b>Teach</b>  Pressing for longer than 10 seconds	Saving the current ambient brightness as the brightness threshold
<b>Set 2</b> Pressing for longer than 10 seconds	Activating the settings saved by the installation engineer
 Pressing for longer than 10 seconds	Switching the presence simulation on or off
<b>Time</b> Pressing for less than 10 seconds	In the next 10 seconds, the run-on time can be changed incrementally using the <b>+/On</b>  or <b>-/Off</b>  buttons.

## Switching on light for the duration of the run-on time

A 2-wire extension or an installation button is connected.

-  In short-time operation, cyclic pulses take place whilst the 2-wire extension at top or bottom or installation button is pressed.
-  Alternatively, press the **Auto Mem** button of the IR remote control for between 1 and 4 seconds. In short-time operation, there is a single pulse after releasing the button.

Light is switched off.

Motion detector operation

- Press the 2-wire extension or installation button for less than 0.4 seconds.

-  If the 2-wire extension or the installation button is pressed again after switch-on, then the run-on time is restarted.

Presence detector operation

- Press the top or full-surface of the 2-wire extension or installation button for less than 0.4 seconds.  
Light is switched on depending on brightness and motion. Movements are evaluated according to the brightness and prolong the run-on time.

### Switching the light off for a period of 3 minutes

**i** This function can only be used in presence detector operation.  
A 2-wire extension or an installation button is connected.

Light is switched on.

- Press the bottom 2-wire extension or installation button.  
The light is switched off for the period of 3 minutes. When movements are detected, the time is restarted.

### Switch on the light for 2 hours

Motions are not evaluated during this time. It is not possible to switch off via a 2-wire extension or installation button.

- Press **2 h On** button of the IR remote control.  
Light is switched on for 2 hours. The motion detector is in automatic operation again after the 2 hours have elapsed.

**i** The time is restarted if actuation is repeated.

**i** Automatic operation is switched on again using the **Auto Mem** button.

### Switch on the light continuously

Motions are not evaluated during this time. It is not possible to switch off via a 2-wire extension or installation button.

- Press the **+/On** button for shorter than 0.4 seconds.  
Light is switched on continuously. The blue LED lights up.

**i** Automatic operation is switched on again using the **Auto Mem** button.

### Switch off the light for 2 hours

Motions are not evaluated during this time. It is not possible to switch on via a 2-wire extension or installation button.

- Press the **2 h Off** button.  
Light is switched off for 2 hours. The device is in automatic operation again after the time has elapsed.

**i** The time is restarted if actuation is repeated.

**i** Automatic operation is switched on again using the **Auto Mem** button.

### Switch off the light continuously

Motions are not evaluated It is not possible to switch on via a 2-wire extension insert or installation button.

- Press the **-/Off** button for shorter than 0.4 seconds.  
Light is switched off continuously. The red LED lights up.

**i** Automatic operation is switched on again using the **Auto Mem** button.

### Adjusting the switch-on brightness

The switch-on brightness is set during commissioning. The switch-on brightness can be adjusted at a later time using the supplied IR remote control.



- Press **Teach** button briefly.
- Within 10 seconds, press the **+/On** or **-/Off** button briefly.  
Each button press extends or shortens the brightness threshold by 10 % of the set value, but by at least 1 lux.

## Saving the current brightness as the switch-on brightness

- Press the **Teach**  button for longer than 10 seconds.  
The current brightness is saved as the switch-on brightness.

## Adjusting the run-on time

The run-on time is set during commissioning. The run-on time can be adjusted at a later time using the supplied IR remote control.

- Press **Time** button briefly.
- Within 10 seconds, press the **+/On**  or **-/Off**  button briefly.  
Each button press extends or shortens the run-on time by 10 % of the set value, but by at least 1 Lux.

## Recalling saved settings

During commissioning, the installation engineer can save the settings made (see Saving settings). These can be recalled if, for example, changes made later are no longer required.

- Press the **Set 2** button for longer than 10 seconds.  
Settings saved by the installation engineer are active again.

## Switching the presence simulation on or off

- Press the  button for longer than 10 seconds.  
The presence simulation is switched on or off alternately. If the function is switched on, the red LED flashes slowly.

 The function cannot be activated until 24 hours after first commissioning.

## 5 Information for electrically skilled persons



### DANGER!

Electrical shock when live parts are touched.

Electrical shocks can be fatal.

Before carrying out work on the device or load, disengage all the corresponding circuit breakers. Cover up live parts in the working environment.

## 5.1 Fitting and electrical connection

### Detection field and range

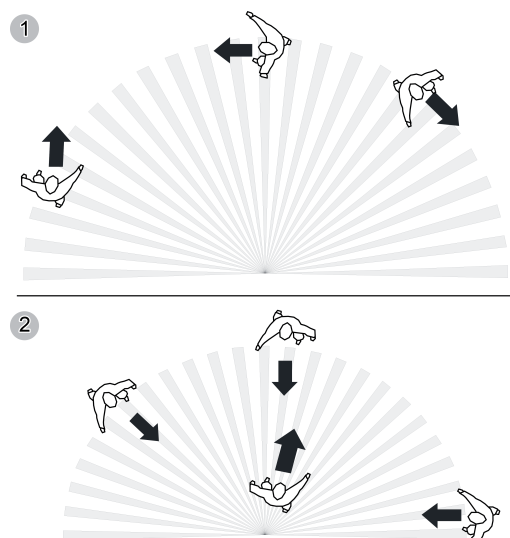

Figure 3: Tangential and radial direction of motion

The device has a detection area of 360°. The diameter of the detection area depends on the installation height and the direction of motions of persons in the detection area (Figure 4).

The detection area becomes larger the greater the installation height, while the detection density and sensitivity are reduced at the same time.

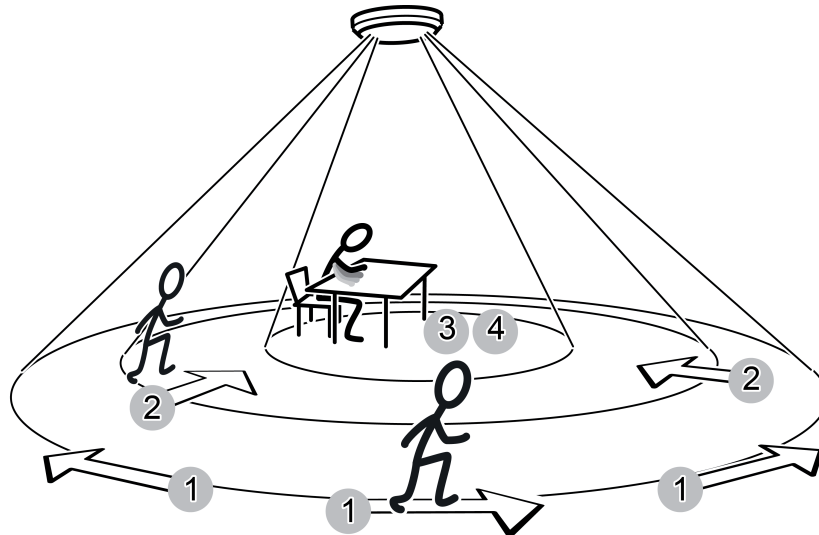

Figure 4: Detection range depending on the direction of movement

#### Diameter of detection area for direction of movement

Installation height	1:	2:	3:	4:
2.20 m	14.5 m	11.5 m	8 m	6 m
2.50 m	16.5 m	13 m	10 m	7 m
3.00 m	20 m	16 m	12 m	8 m
3.50 m	23 m	18.5 m	14 m	9 m
4.00 m	26 m	17 m	14.5 m*)	– *)
5.00 m	28 m	18 m	15 m*)	– *)
6.00 m	29 m	19 m	– *)	– *)

- 1: Range for tangential movement on the ground
- 2: Range for radial movement on the ground
- 3: Range for typical movements at desks, e.g. torso movement
- 4: Range of fine detection at desks, e.g. mouse movements

\*) When used as a presence detector: Installation height should not be more than 3.5 m, otherwise fine detection is not possible.

#### Selecting the installation location

For use as a presence detector, the device is installed, for example, above a workplace and monitors the surface below it. For use as a motion detector, the device is installed, for example, in the hallway.

- Select a vibration-free installation location. Vibrations can lead to unwanted switching.
- Avoid interference sources in the detection area. Interference sources, e.g. heaters, ventilation, air conditioners, and cooling light bulbs can lead to unwanted detections.

- i The detection area can be limited in order to minimize the influence of interference sources. For this, use the push-on cover (see Limiting the detection area with the push-on cover) or switch off individual sensors (see Limiting the detection area).

### Aligning the device

The device has three independent PIR sensors for motion detection(Figure 5).

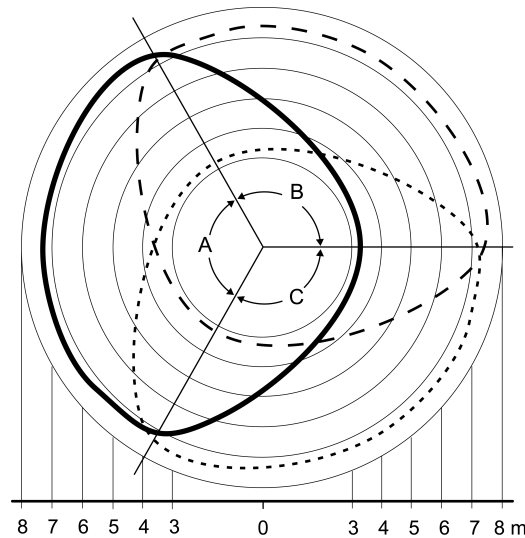

Figure 5: Detection field areas A, B and C, installation height 2.50 m

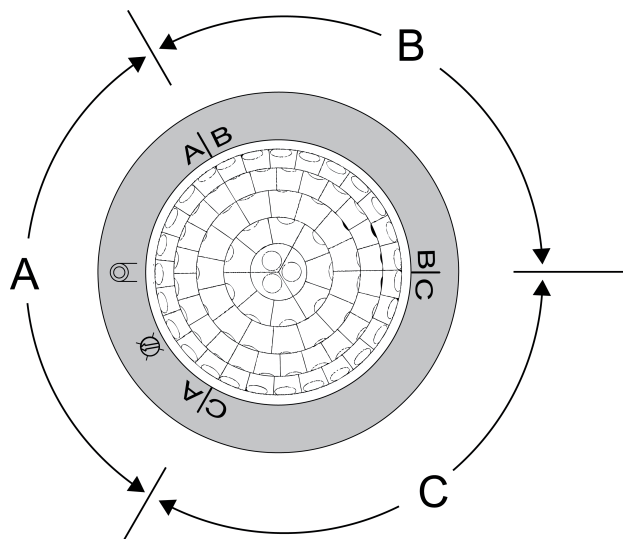

Figure 6: Arrangement of the areas A, B and C

- Align the connection box (1) in such a way that the areas A, B and C match the structural conditions. The arrangement is clearly evident under the decor ring (Figure 6).



## Preparations for installation

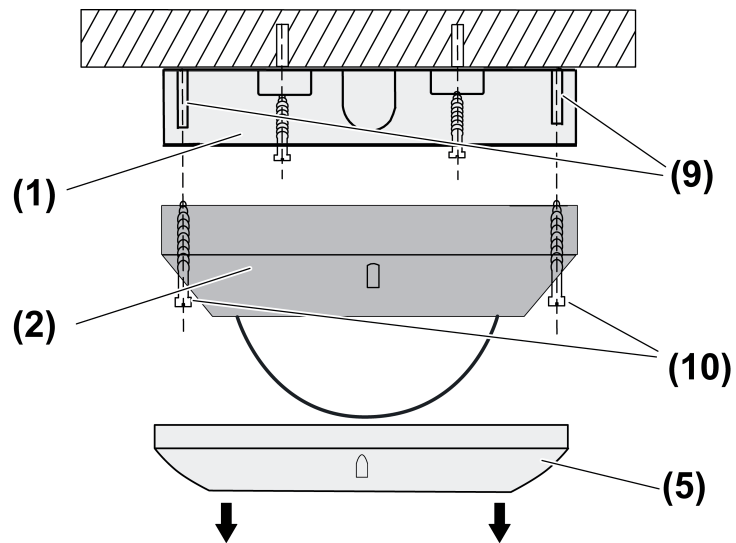

Figure 7: Fitting

- (1) Connection box
- (2) Sensor top
- (5) Decor ring
- (9) Fastening pins
- (10) Screws
  - Pull off the decor ring (5) (Figure 7).
  - Loosen the screws (10) (Figure 7).

## Installing the connection box

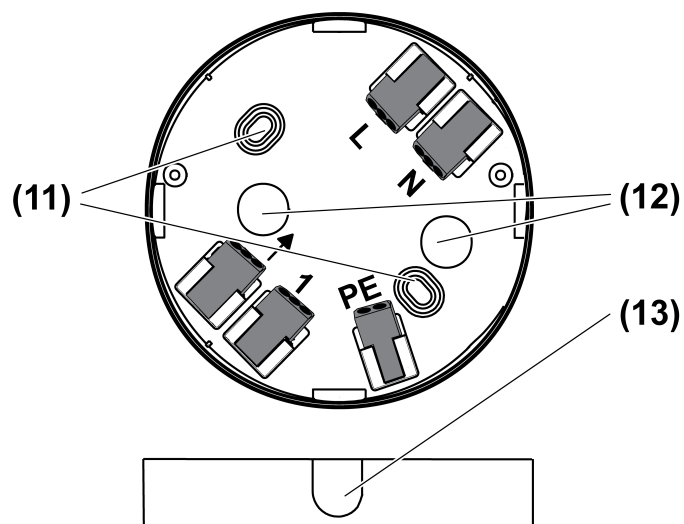

Figure 8: Connection box

- (11) Fastening holes
- (12) Cable entry, surface-mounted
- (13) Thin points for optional cable entries

- Align the device (for the position of areas A, B, C, see Aligning the device) - the brightness sensor should, if possible, be located on the side away from the window. This reduces the effects of scattered light.
  - For an additional flush-mounted cable entry or surface-mounted cable entry, break out the appropriate thin point (13) (Figure 8).
  - Fastening the connection box (1) through holes (11) (Figure 8).
- i** Alternatively, the device can also be mounted on a 60 mm appliance box. The screws are not included in the scope of delivery.

## Connecting the device

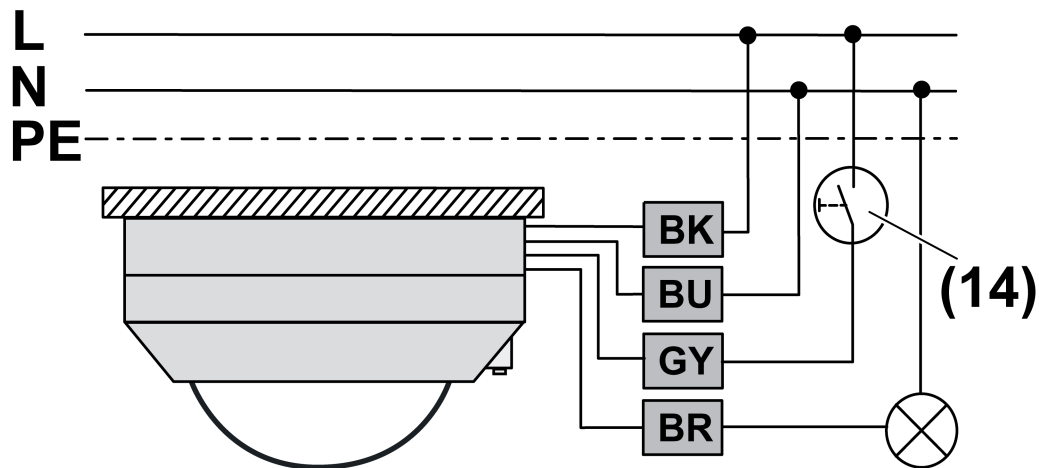

Figure 9: Connection diagram, single device

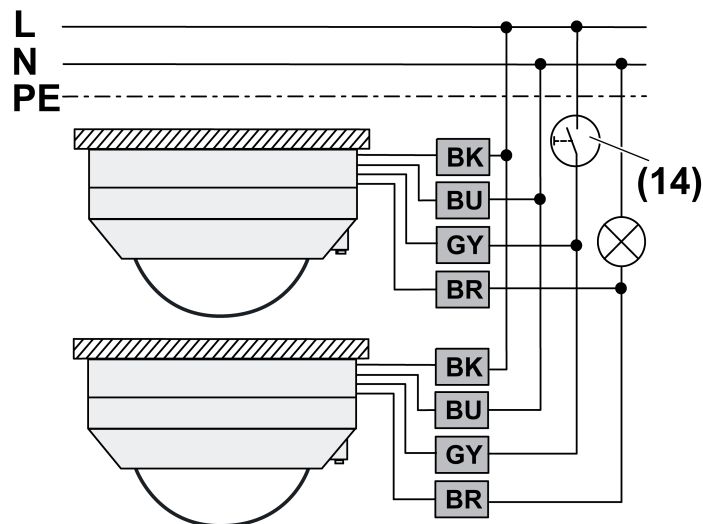

Figure 10: Connection diagram, parallel circuit for expanding the detection area

Max. power cable length 100 m. This takes into account all the connecting cables between the devices and lamps.

Do not connect more than five devices in parallel.

Connect all devices to the same outer conductor.

Set all the devices to the same device function (motion detector or presence detector).

**i** The connection in parallel does not increase maximum connected load.

- Connect the sensor top according to the connection diagram (Figure 9) or switch the sensor tops according to the circuit diagram (Figure 10).
- If multiple miniature circuit breakers supply dangerous voltages to the device or load, couple the miniature circuit breakers or label them with a warning, to ensure disconnection is guaranteed.

### Connection assignment

black, BK, L	External conductor
brown, BR, ↓	Switched external conductor
blue, BU, N	Neutral conductor
grey, GY, 1	Installation button connection
PE	Earth conductor

- Optionally, connect the installation button (14) (Figure 9) or (Figure 10). This is only necessary if manual operation is also desired.
- i** Lit installation buttons may only be connected if they have an N terminal.
- i** In the case of single devices, a 2-wire extension can be used as an alternative to the installation button (14).
- Screw the sensor top (2) to connection box (1) with screws (10) and mounting pins (9) (Figure 7).

### Limiting the detection area using the push-on cover

The push-on cover can be used to limit the detection area, e.g. in order to mask out interference sources.

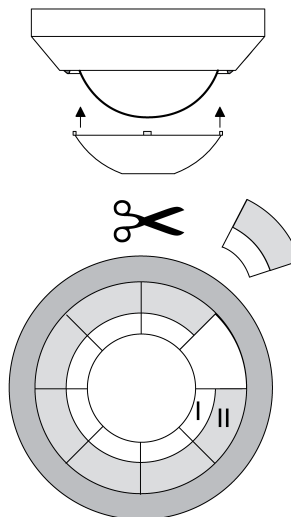

Figure 11: Push-on cover

Cover size	Range on the ground (mounting height 3 m)
Complete push-on cover	Ø approx 4.5 m
Area I cut out	Ø approx. 7.5 m
Areas I + II cut out	Ø approx. 12 m
without push-on cover	Ø approx. 20 m

- Pull off push-on cover.

- Using scissors, cut out push-on cover along the marked lines as required.
  - Push on push-on cover.
- i** Alternatively, the detection area can also be limited by switching off individual sensors (see Commissioning).

## 5.2 Commissioning

### Insert battery into IR remote control

- i** To avoid contact problems, keep the contacts of batteries and device free of grease.



#### CAUTION!

**Risk of chemical burns.**

**Batteries can burst and leak.**

**Replace batteries only with an identical or equivalent type.**

- Insert the supplied battery with correct polarity (see IR remote control imprint)

The operation and necessary settings are carried out using the IR remote control for the installation engineer (see Accessories).

- i** If multiple devices are within the range of the IR remote control, then align it so that only the device to be operated can receive the signals.



### Button assignment of the installation engineer IR remote control

Button	Function
<b>1 s</b> ☀	Short time operation
<b>30 s</b> ☀, <b>2 min</b> ☀, <b>5 min</b> ☀, <b>30 min</b> ☀	Set run-on time
<b>Teach</b> ☀ Pressing for longer than 10 seconds	Saving ambient brightness as brightness threshold
☾, ☀, 🏠, ☀	Setting the brightness threshold
<b>0-1 h</b> ☀	Setting individual run-on time
<b>Dyn.</b> ☀ Pressing for longer than 10 seconds	Switching on the dynamic run-on time
<b>PIR A, PIR B, PIR C, PIR A-C</b> Pressing for longer than 10 seconds	Switching the PIR sensors on/off
<b>PIR A, PIR B, PIR C</b> Pressing for less than 10 seconds	In the next 5 seconds, use the <b>25 %</b> , <b>50 %</b> , <b>75 %</b> and <b>100 %</b> buttons to set the sensitivity of the appropriate PIR sensor
<b>25 %</b> , <b>50 %</b> , <b>75 %</b> , <b>100 %</b>	Setting the sensitivity
<b>Mode</b> 🏠 Pressing for longer than 10 seconds	Switching on the Presence detector device function
<b>Mode</b> 👁 Pressing for longer than 10 seconds	Switching on the Motion detector device function
<b>Eco</b> 🍃	No function is saved for this device
<b>Test 100 h</b> Pressing for less than 10 seconds	Switch on test operation
<b>Test 100 h</b> Pressing for longer than 10 seconds	On for 100 hours
<b>Set 1</b> Pressing for longer than 10 seconds	Save any changes made for later recall using the <b>Set 2</b> button of the end customer IR remote control

<b>On/Off III.</b> Pressing for longer than 10 seconds	Switch on/off switch-off warning
<b>Prog Func</b>	No function is saved for this device
<b>Reset</b> Actuation of between 4 seconds and 10 seconds	Switching off the functions: Dynamic run-on time, switch-off prewarning, on for 100 hours, test operation
<b>Reset</b> Pressing for longer than 10 seconds	Restoring to factory settings

## Switching on a device function

The device can work either as a motion detector or presence detector.

- Press the **Mode**  or **Mode**  button.  
The device works either as a motion detector or presence detector.
-  When changing the device function, the settings of the previous device function are saved and reactivated on changing again.

## Setting the sensitivity

The sensitivity can be set individually for each PIR sensor.

- Press the **PIR A**, **PIR B** or **PIR C** for less than 10 seconds.
- Within 5 seconds, press the **25 %**, **50 %**, **75 %** or **100 %** button.  
Sensitivity is set.

## Limiting the detection area

The detection area of the motion detector can be limited by switching off one or two PIR sensors. Since the detection areas of the PIR sensors overlap, there is no distinct demarcation of the blocked out detection area. If all the PIR sensors have been switched off, then the device works as a twilight switch.





- Press the **PIR A**, **PIR B** or **PIR C** button for longer than 10 seconds.  
The appropriate PIR sensor is switched off and the detection area is limited.
-  By pressing the **PIR A-C** button all the PIR sensors are switched on again at 100 % sensitivity. Individual PIR sensors can be switched off by setting a sensitivity for the PIR sensor.

## Setting the switch-on brightness

One of four predefined brightness thresholds (see table) or one individual brightness threshold can be set (see Saving current brightness as the switch-on brightness). If the device is set as a motion detector, then the brightness is measured on the device. If the device is set as a presence detector, then the brightness is measured on the work surface.

- Press the appropriate button (see table).

## Brightness thresholds

Icon	Device function, motion detector	Device function, presence detector
	5 lux	200 lux
	10 lux	500 lux
	150 lux *	1000 lux
	Brightness-independent - day operation	Brightness-independent - day operation

\* Setting for stairways according to DIN EN12464-1, 2003-03





## Saving the current brightness as the switch-on brightness

The Teach function can be used to save the current brightness as a switch-on brightness.

- i** Do not shade the device during the measuring process.
  - Create the desired lighting situation, e.g. switch light on or off.
  - Press the **Teach**  button for longer than 10 seconds.
 

The Teach function is activated, the current brightness is saved as the switch-on brightness and is used after a maximum of 3 minutes.
- i** If a value greater than 2000 lux is saved, the motion detector switches to day operation independent of the brightness.

## Setting fixed run-on time

- Press **30 s** , **2 min** , **5 min**  or **30 min**  button.
- i** If the run-on time is shortened, then it only becomes active after the device has switched off once. To cancel a running run-on time, set the special function Continuous on for example and then switch back to Automatic operation (see Operation).

## Setting individual run-on time

The individual run-on time can be set within a range of 10 seconds to 60 minutes. One of the fixed run-on times can be set again at any time.

- Press **0-1 h**  button.
 

Run-on time starts.
- When the required run-on time is reached, press **0-1 h**  button.
 

The device saves the run-on time.
- i** If the run-on time is shortened, then it only becomes active after the device has switched off once. To cancel a running run-on time, set the special function Continuous on for example and then switch back to Automatic operation (see Operation).

## Setting the dynamic run-on time

The device adapts the run-on time to the motion situation.

- Press the **Dyn.**  button for longer than 10 seconds.
 

The dynamic run-on time is activated.
- i** To switch off the function, press the **Reset** button for between 4 and 10 seconds

## Switching on short time operation

- Press **1 s**  button.
- i** No individual or dynamic run-on time can be set in short time operation.
- i** To switch off short-time operation, set a fixed or individual run-on time.

## Switching on switch-off warning

Switch-off warning is switched off.

- Press the **On/Off**  button for longer than 10 seconds.
 

Switch-off warning is switched on. If pressed again, the switch-off warning is switched off again.
- i** The function is also switched off if the **Reset** button is pressed for between 4 and 10 seconds.

## Switching on the function as a twilight switch

All the PIR sensors must have been switched off for the device to work as a twilight switch.

- Press the **PIR A**, **PIR B** and **PIR C** buttons for longer than 10 seconds.
 

The device works as a twilight switch as soon as the last PIR sensor has been switched off. The red LED lights up.
- i** If day operation is set as the switch-on brightness, the light remains off continuously.
- i** It is not possible to switch via a 2-wire extension or installation button.

## Switch on test operation

The test operation is used for testing the detection area. In test operation, the device operates independently of the brightness. All the other settings remain unchanged. Detected motions are signalled by the blue status LED.

- Press the **Test 100 h** button for between 4 and 10 seconds.  
Test operation is switched on for 5 minutes.
- ❗ By pressing the **Auto Mem** button of the IR remote control for end customers, you can switch to automatic operation at any time (see Operation).
- ❗ The function is also switched off if the **Reset** button is pressed for between 4 and 10 seconds.

## Switch On for 100 h

This function is used to burn in fluorescent lamps.

- Press the **Test 100 h** button for longer than 10 seconds.  
The lamps are switched on for 100 hours. The device is switched back to automatic operation again after the time has elapsed.
- ❗ During the 100 hours, no switching is possible via 2-wire extension, installation button or IR remote control, movement signals are not evaluated.
- ❗ To switch off the function, press the **Reset** button for between 4 and 10 seconds.

## Saving settings

Save the settings so that, if necessary, the end customer can recall them using the **Set 2** button. No values are saved in the as-delivered state.

- Press the **Set 1** button for longer than 10 seconds.  
The following settings are saved: Device function, sensitivity of PIR A-C, detection angle, switch-on brightness, run-on time, dynamic run-on time, short-time operation, switch-off prewarning. Previously saved values are overwritten.

## Restoring the device to factory settings

- Press the **Reset** button for longer than 10 seconds.

Function	Value
Device function	Motion detector
Operating mode	Automatic operation
Sensitivity of PIR A-C	100 %
Detection angle	360°, PIR A-C switched on
Switch-on brightness	10 lux
Run-on time	2 minutes
Dynamic run-on time	switched-off
Short time operation	switched-off
Switch-off warning	switched-off
Presence simulation	switched-off
Test operation	switched-off

- ❗ If the **Reset** button is pressed for between 4 and 10 seconds, only a few functions are terminated (see button assignment of Installation engineer IR remote control).

## 6 Appendix



Remove empty batteries immediately and dispose of in an environmentally friendly manner. Do not throw batteries into household waste. Consult your local authorities about environmentally friendly disposal. According to statutory provisions, the end consumer is obligated to return used batteries.

## 6.1 Technical data

Rated voltage	AC 110 ... 230 V ~
Mains frequency	50 / 60 Hz
Ambient temperature	-5 ... +45 °C
Standby power	max. 0.3 W
Circuit breaker	max. 16 A
Contact type	ε
Detection angle	360 °
Dimensions Ø×H	103×66 mm
Installation height	3 m
Detection area	Ø approx. 20 m
Sensitivity	25 ... 100 %
Brightness setting	approx. 5 ... 2000 lx (and day operation)
Run-on time	approx. 10 s ... 30 min
Short time operation	
pulse duration	approx. 0.5 s
pulse stop	approx. 3 s
Switching current at 35 °C	
Ohmic	16 A (AC1)
Fluorescent lamps	4 AX
Minimum switching current AC	100 mA
Connected load at AC 230 V~ and 35 °C	
Incandescent lamps	2300 W
HV halogen lamps	2000 W
Electronic transformers	1500 W
Inductive transformers	1000 VA
HV-LED lamps	typ. 400 W
Compact fl lamp.	typ. 400 W
Fluorescent lamps, uncompensated	920 VA
Capacitive load	690 VA (560 µF)
Connected load at AC 110 V~ and 35 °C	
Incandescent lamps	1150 W
HV halogen lamps	1000 W
Tronic transformers	750 W
Inductive transformers	500 VA
HV-LED lamps	typ. 200 W
Compact fl lamp.	typ. 200 W
Fluorescent lamps, uncompensated	460 VA
Capacitive load	345 VA (560 µF)
Connection	
single stranded	1.0 ... 2.5 mm <sup>2</sup>
finely stranded with tin-plated conductor ends	0.75 ... 1.5 mm <sup>2</sup>
Number of extension units	
Unlit push-buttons	unlimited
Extension insert, 2-wire	unlimited
Total length of extension unit cable	max. 100 m
Total length power cable	max. 100 m
IR remote control	
Battery type	1×lithium CR 2025

## 6.2 Troubleshooting

### Device does not switch on

Cause 1: The ambient brightness is greater than the set brightness value.  
Set brightness value.



Cause 2: Device does not detect any motions.

Increase sensitivity.

Switch on all sensors.

Cause 3: Off for 2 hours or Continuous off is activated

Switch on automatic mode.

### **Device switches on without motions**

Cause 1: Presence simulation is activated. Device switches at saved times.

Switch the presence simulation off.

Cause 2: Interference sources in the detection area.

Remove interference sources if possible.

Reduce sensitivity.

Limit detection area.

### **Device constantly switches on and off during motion**

Cause 1: Short-time operation is switched on.

Set a longer run-on time.

### **Device switches off despite motion**

Cause 1: The device does not detect any motion.

Increase sensitivity.

Cause 2: Detection area is limited because a sensor was switched off.

Switch on all sensors.

Cause 3: Detection area is limited by push-on cover.

Check the push-on cover.

### **Device does not switch off**

Cause 1: Interference sources in the detection area, device detects motions constantly.

Remove interference sources if possible.

Reduce sensitivity.

Limit detection area.

Cause 2: On for 2 hours, Continuous on or On for 100 hours is activated.

Switch on automatic mode.

### **The device does not respond to IR remote control, red LED does not flash.**

Cause 1: IR remote control out of range.

Go closer to the motion detector.

Cause 2: Battery in IR remote control is empty.

Change battery (see back of the IR remote control)

### **The device does not respond to IR remote control, red LED flashes, blue LED does not**

Cause: Device is receiving an IR signal. Function or setting cannot be executed.

## **6.3 Accessories**

IR remote controller PIR 1 (installer)

Order No. 2382 00

## **6.4 Warranty**

The warranty follows about the specialty store in between the legal framework as provided for by law

Please submit or send faulty devices postage paid together with an error description to your responsible salesperson (specialist trade/installation company/electrical specialist trade). They will forward the devices to the Gira Service Center.

**Gira**  
**Giersiepen GmbH & Co. KG**  
Elektro-Installations-  
Systeme

Industriegebiet Mermbach  
Dahlienstraße  
42477 Radevormwald

Postfach 12 20  
42461 Radevormwald

Deutschland

Tel +49(0)21 95 - 602-0  
Fax +49(0)21 95 - 602-191

[www.gira.de](http://www.gira.de)  
[info@gira.de](mailto:info@gira.de)